

# OPERATING INSTRUCTIONS FOR E8 CONTROL

## E8 Control

### Right Side

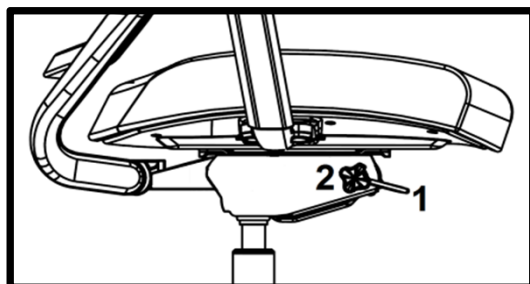

### Left Side

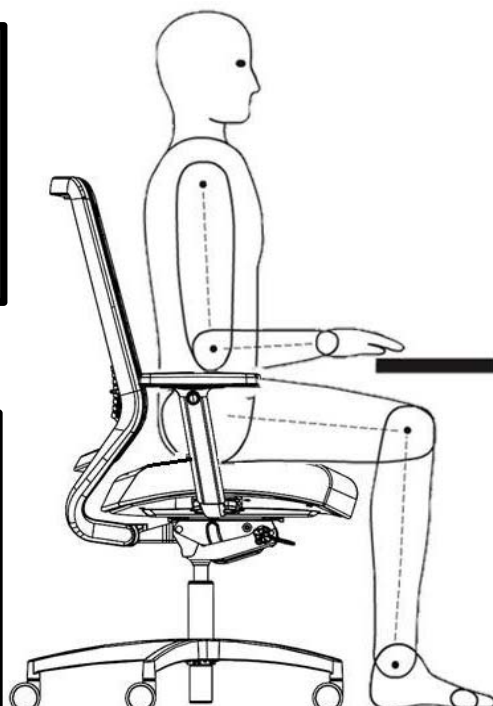
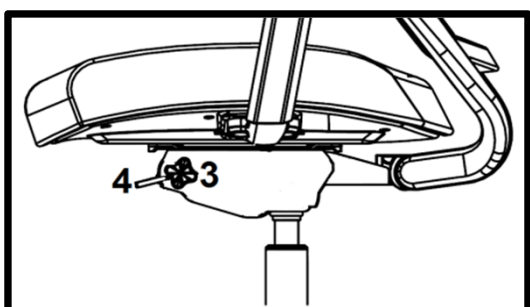

1. Seat Height Adjustment
2. Tension Control
3. Seat and Back Tilt Adjustment
4. Seat Slider (E8-SS7 only)

Shown: E8

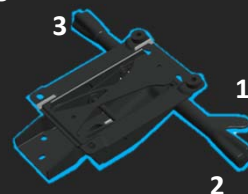

Shown: E8-SS7

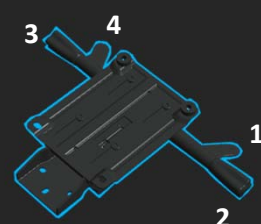

## E8 Control

### Right Side

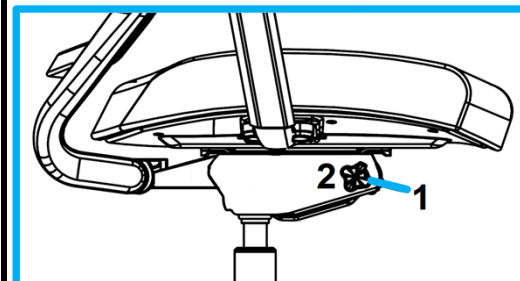

### Left Side

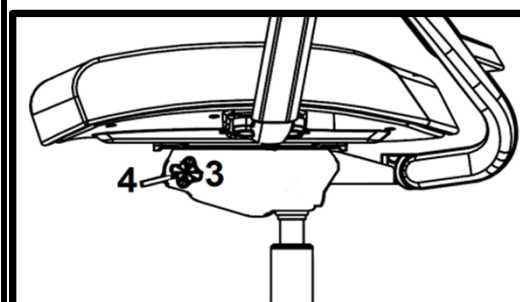

### Paddle (1): Seat Height Adjustment

To raise the seat height, stand up (or raise body so that there is no pressure on the seat), and lift the paddle to the desired seat height.

To lower the seat height, sit in the chair and lift the paddle to the desired seat height.

## E8 Control

### Right Side

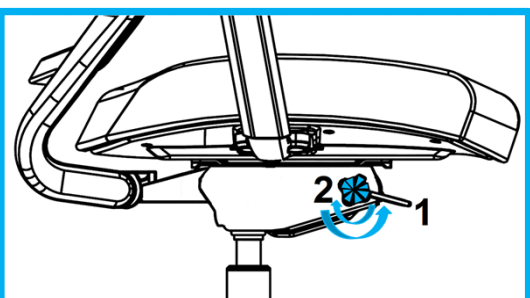

### Left Side

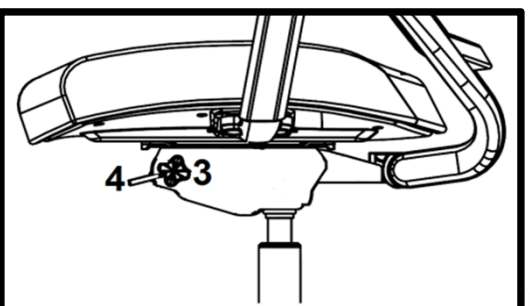

### Knob (2): Tension Control

To increase tension, while seated, pull knob out, and turn knob toward the front of the seat (clockwise).

To decrease tension, while seated, pull knob out, and turn knob toward the back of the seat (counter-clockwise).

## E8 Control

### Right Side

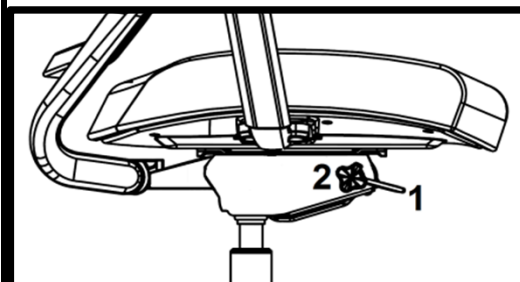

### Left Side

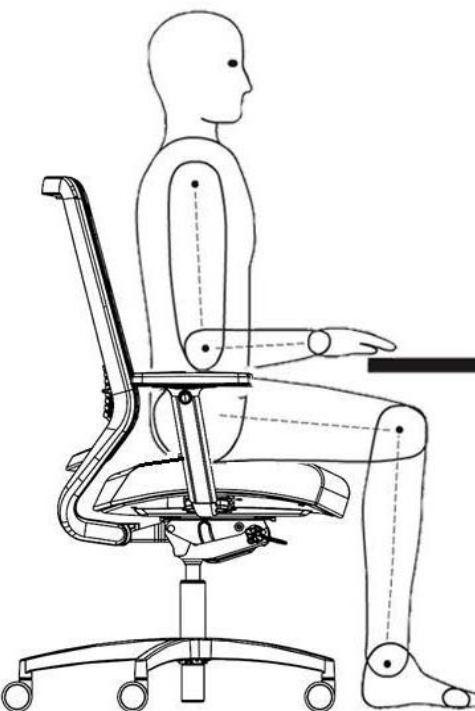
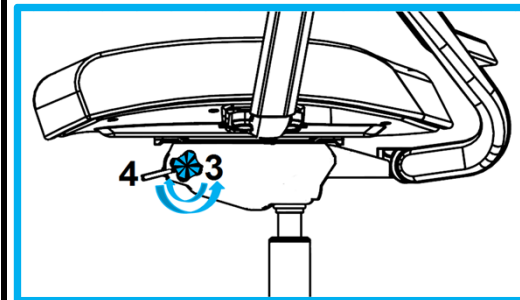

### Knob (3): Synchronized Seat and Back Tilt Adjustment

To adjust, turn the knob toward the front of the seat (counter-clockwise) to unlock, then lean back to adjust the seat and back posture. Turn the knob toward the back of the seat (clockwise) to lock into the desired position (3 locking positions available).

Note: To change locking positions, user must lean back (apply pressure) in order to disengage the lock.

**\*E8-SS7 Control Only\***

**Right Side**

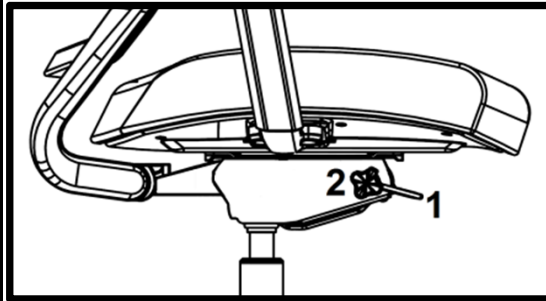

**Left Side**

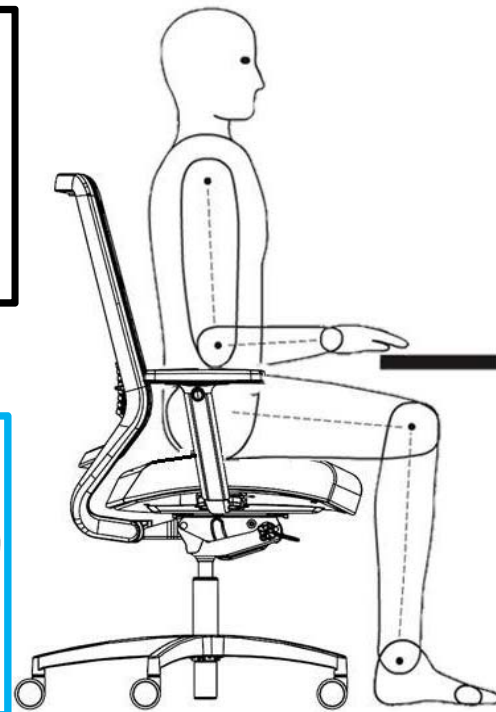
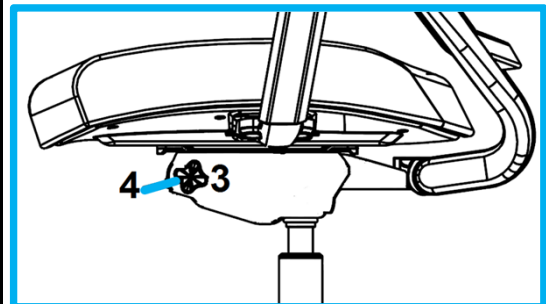

**E8-SS7 Control Only**

**Paddle (4):  
Seat Slider**

To adjust, sit on the chair, pull the paddle up, and slide the seat forward or backward to adjust the seat depth.

Note: SS7 seat slider offers 2" of travel.